

POS_T - Lighting



Lighting at the point of sale generates emotions.

Light is one of the key success factors at the Point of Sale.

Light increases visibility, visibility increases sales. Why? The shopper can only buy what he sees!

Approx. 90 % of the information taken in by the human eye is retained by our sensory memory for only a split second. Therefore it is vital that your product is „highlighted“ to its best advantage and is registered and retained by the shopper.

Lighting in the immediate vicinity of the product on a shelf or in a display draws the attention of the shopper. Good shelf illumination places the focus on the product – not the lighting itself.

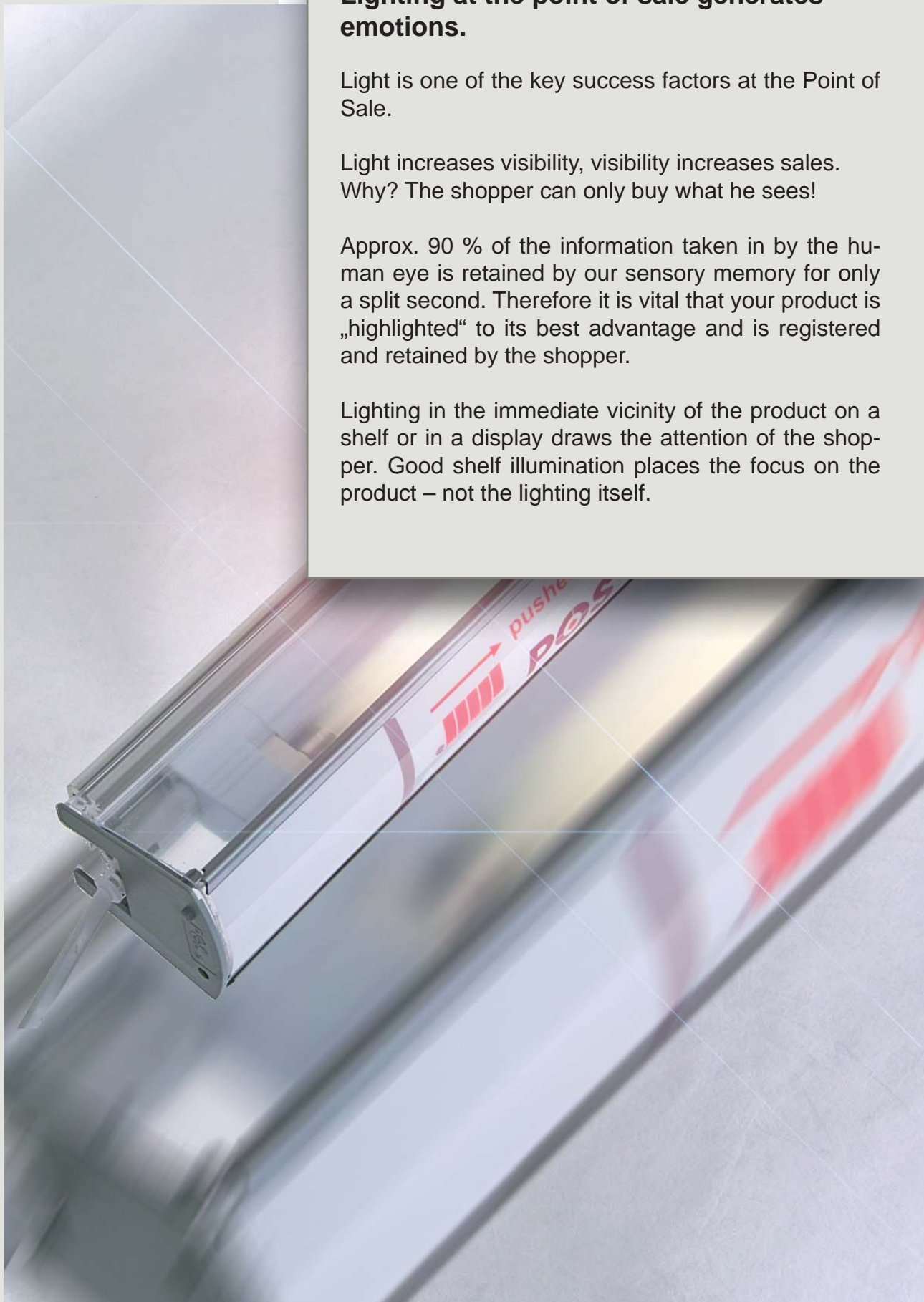

Front Edge Shelf Lighting - Lighting and Information

POS τ - Brandline

POS τ - Light

The effect of Front Edge Shelf Lighting is to optimize the visibility of product facings. The lighting elements are positioned ahead of the products to highlight the front facings and not the top of the product or the back of the shelf. Such ideal product visibility improves shopper orientation at the point of sale and promotes impulse buying.

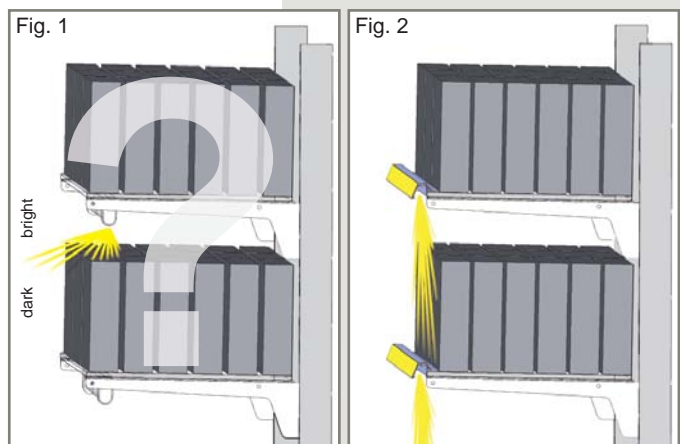

Fig. 1

Light sources **above or behind** the product immerse the front facing in shadows, distracting from the product.

Fig. 2

Light sources **in front** of the product highlight the front facing, drawing attention to the product.

POS τ - Brandline

POS τ - Brandline shelf lighting is extremely slim and enables brands or product segments to be singled out on the shelf without inhibiting product visibility.

Translucent promotional or information strips are inserted into the clear front. Integrated LED's create an atmospheric backlit.

Brandline lighting can easily be mounted on all commercially available shelving (glass, metal, plastic, wood) using double-sided adhesive or magnetic fittings, providing optimal illumination and visibility of the product facings below the shelf.

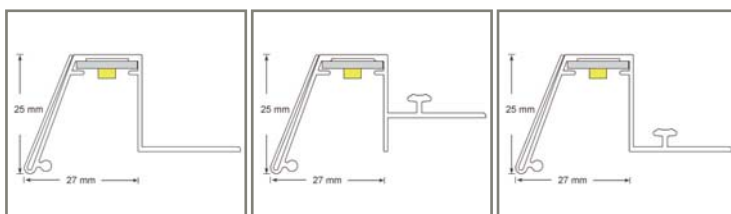

POS T - Light



POS T - Light is the distinctive front of shelf illumination system to highlight brands and assortments.

POS T - Light is compatible with all shop fitting systems to installed in front of the shelf. The POS T - Light can be equipped with colour filters for special lighting effects.

Promotional slide inserts in the UV resistant lighting covers convey emotional messages and brand images to the shopper.

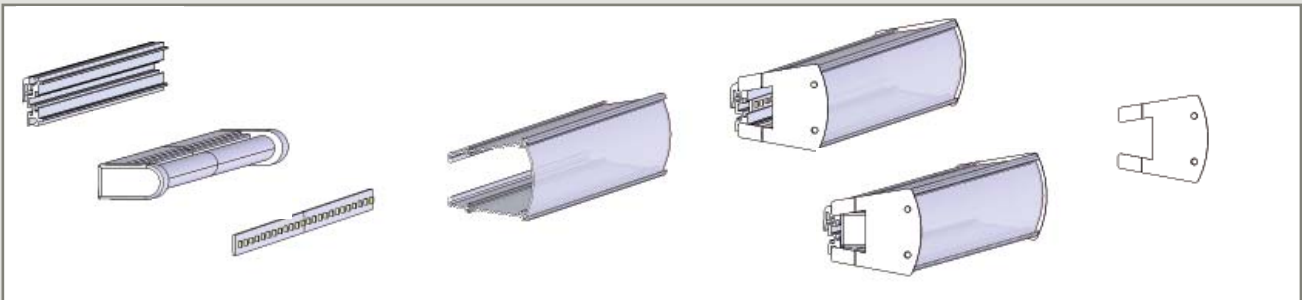

Frame profile made of anodized aluminium alloy, with grooves for mounting lighting cover, lighting elements, scanner rails or other promotional elements.

Transparent lighting cover with tinted outside corners and internal and external insert guides (front H 51 mm, top/bottom H 38 mm) for slides, decorating strips, transparencies, etc.

End caps with cable management and connection pins. Breakaway points permit solid lighting feed-through.



T5 Version

Equipped with modern T5 lights (GS certified, power saving electronic ballast) and a light emit-tance of 360° the POS T - Light can simultaneously illuminate the promotion insert as well as pro-ducts displayed above and below it.



LED Version

Equipped with LED lights the POS T - Light is highly efficient and cost effective due to extremely low current consumption and a very high service life of up to 50,000 h.

Particularly suitable for temperature sensitive pro-ducts, as heat emission is minimal.

Under Shelf Lighting

POS T - Built-In LED

POS T - Built-In LED

the under shelf light for all current axial dimensions. The under shelf mounting is self-adhesive or magnetic.

Perfect illumination of facings with the POS T - Built-In LED is achieved through inclined product presentation (e.g. use of POS T - pusher plate inclined).

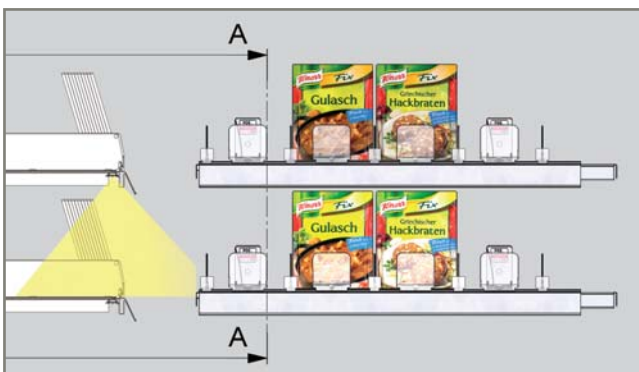

Optimal supply of power to each shelf utilizing the POS T - System.

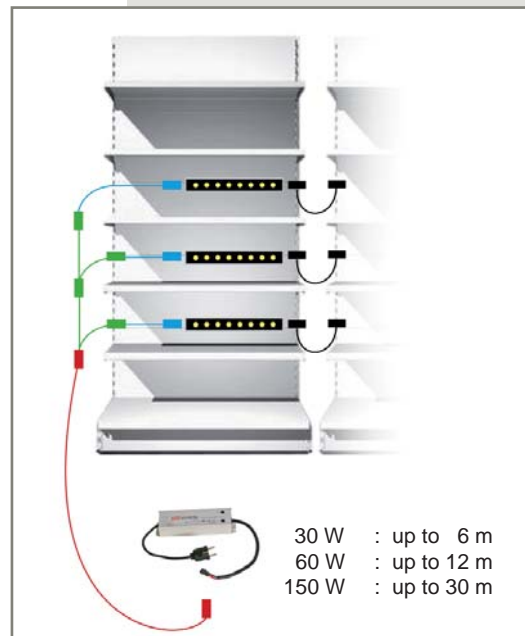

Energy efficiency / Comparison LED - T5

(Example POS T - Light L = 100 cm)

Cost Analysis	Unit	LED	T5
Power consumption per light L = 100 cm	W	4.50	21.00
Service performance per annum at 16h daily, 300 days of the year	h	4,800.00	4,800.00
at power consumption / light	kWh	21.60	100.80
Price per kWh	EUR	0.13	0.13
Annual energy costs / light	EUR	2.81	13.10
Service life	h	50,000.00	6,000.00
Service life for annual operation: 16h daily for 300 days	Years	10.42	1.25
Costs for lamps L = 100cm	EUR	75.00	16.00
Loss of value due to wear and tear / light / year	EUR	7.20	12.80
Service costs for lamp replacement / year (50.00 EUR/h, duration 0.5h)	EUR	2.40	20.00
Total costs per year / light	EUR	12.41	45.90

Savings per year by using LED as compared to T5

72.97%

Effect Lighting

POS τ - Magic Divider



Magic Divider

Novelties or premium products deserve special attention. The shelf divider lighting „POS τ - Magic Divider“ attracts the shopper’s attention as if by magic, ensuring that your “star” is not lost amidst the assortment. Colour effects are added by inserting translucent strips.

Illuminated Promotional Slides

POS τ - Slide Light

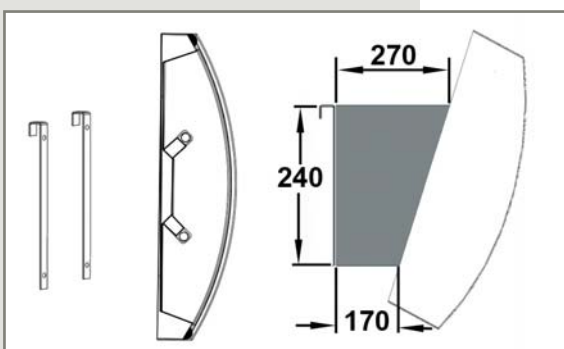

Slide-Light A2

Labelling a product line or promoting a brand – the lightweight POS τ - Slide Light (weight < 2 kg) can easily be installed on plain surfaces. In an upright oder inclined position with additional fittings the Slide Lights can be mounted onto the back panels of almost all shelving systems.

Lighting Solutions

The POS T - „Toolbox“

Individual Solutions

The POS T - “Toolbox” of proven standard components provides a solid and efficient platform.

The toolbox combined with our creative resource offers you the desired advantage for your products at the Point of Sale!

LED Strips

With plug and socket, cold white lighting, two different standard lengths

Adapter T-Bus

Low voltage rail system for power supply; compatible to all commercially available shelving

Wiring

Connection cables, extension cables, universal AC adaptors, etc.

Cable management system

ensures a clean, tidy and safe environment

Accessories

Transparent inserts and promotional slides for POS T - Light, POS T - Brandline and POS T - Slide Light

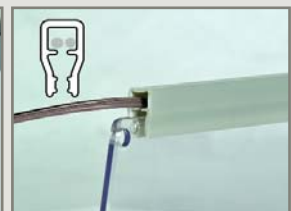
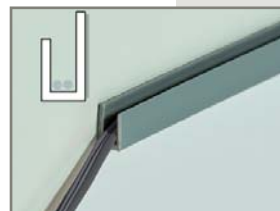
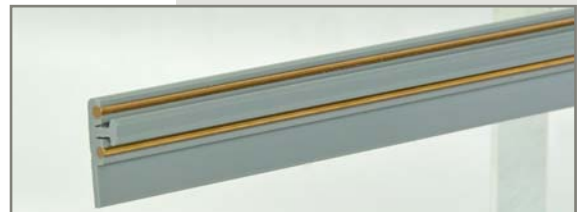
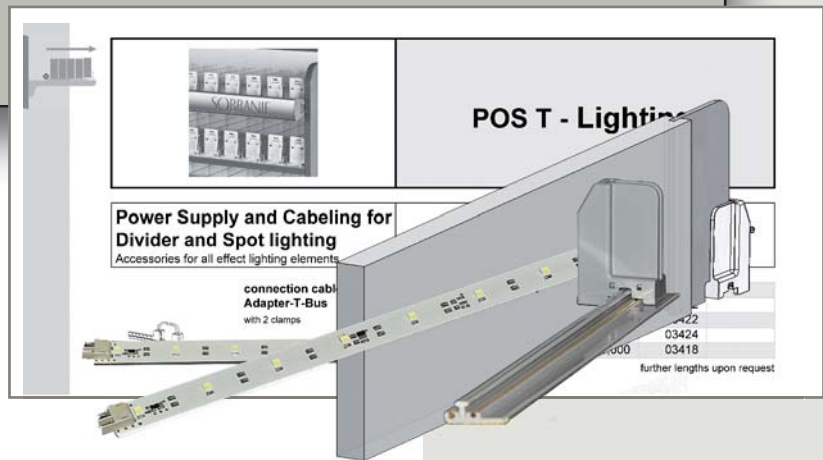

Individual Lighting
Bespoke Solutions
 – Examples

Alluring

Illuminated highlights specially designed for your products.



“Primus inter pares”

(first choice amongst others)

- Present your product in consumers focus

... for more success at the Point of Sale



LED - Frame

Individual frames developed to your specifications.

Prominent

Illuminated highlights specially designed for your products.



The POS T - push feed system improves the presentation of almost every product. Send for our large range to optimize your product display.

